



SJIII 4632

ELECTRIC SCISSOR LIFTS

STANDARD FEATURES

- Drivable at full height
- Variable speed, rear two wheel hydraulic drive
- Dual holding brakes
- Proportional controls for drive & lift functions
- 4' (1.22 m) Roll out extension deck
- 24V DC power source
- Low voltage battery protection
- Up to 30% Gradeability
- Solid rubber, non-marking tires
- Pothole protection system
- 110V AC outlet on platform with GFI
- 28 mph wind rating (12.5 m/s)
- Tilt alarm with drive & lift cut-out
- All motion audible alarm
- Lanyard attachment points
- Operator horn
- Hinged railing system
- Forklift pockets and tie down/lift lugs
- Relay based control system
- Color coded and numbered wiring system
- Telematics ready

* Aircraft protection package includes other listed options as part of package.

† Standard lead times may be increased when optional equipment is added, consult factory.

‡ Capacities, and machine weights may differ when options are added.

SJIII 4632 ELECTRIC SCISSOR LIFTS

Dimensions	SJIII 4632
A Work Height	38' (11.58 m)
B Raised Platform Height	32' (9.75 m)
C Lowered Platform Height	48.5" (1.23 m)
D Overall Width	46" (1.17 m)
E Overall Length	91" (2.31 m)
F Stowed Height (Rails Up)	88" (2.24 m)
G Stowed Height (Rails Down)	74" (1.88 m)
H Platform Width (Inside Dimension)	42" (1.07 m)
I Platform Length (Inside Dimension)	84" (2.13 m)
Specifications	SJIII 4632
Extension Deck (Roll Out)	4' (1.22 m)
Ground Clearance (Stowed)	3.5" (8.89 cm)
Ground Clearance (Raised)	0.75" (1.91 cm)
Wheelbase	69" (1.75 m)
Weight	5,075 lbs (2,302 kg)
Gradeability	25%
Turning Radius (Inside)	47.5" (1.21 m)
Turning Radius (Outside)	93.5" (2.37 m)
Lift Time (With Rated Load)	59 sec
Lower time (With Rated Load)	49 sec
Drive Speed (Stowed)	2 mph (3.2 km/h)
Drive Speed (Raised)	0.6 mph (1 km/h)
Maximum Drive Height	Full Height
Capacity (Overall)	700 lbs (318 kg)
Distributed Capacity (Main Platform)	450 lbs (204 kg)
Distributed Capacity (Extension Deck)	250 lbs (113 kg)
Local Floor Load (With Rated Load)	220 psi (1517 kPa)
Overall Floor Load (With Rated Load)	204 psf (10 kPa)
Maximum # of Persons	2
Wind Rating	28 mph (12.5 m/s)
Tire Type	Solid, N/M
Tire Size	16 x 5 x 12

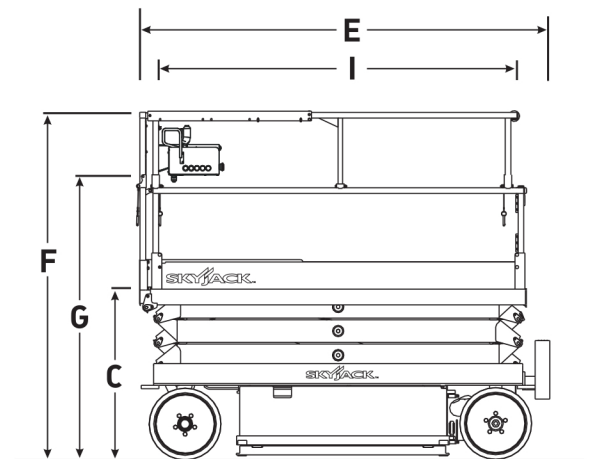
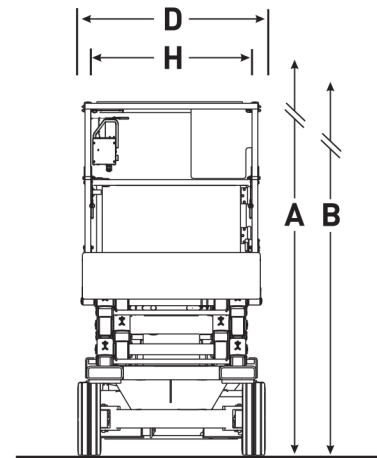

Skyjack Head Office

55 Campbell Rd. Guelph, ON Canada N1H 1B9
 Sales Inquiries: 1-877-755-4387 (1-877-SJLIFTS)
 Main Switchboard: 1-800-265-2738
 Phone: 519-837-0888
 Fax: 519-837-8104
 Email: skyjack@skyjack.com
 www.skyjack.com

This brochure is for illustrative purpose only and based on the latest information at the time of printing. Skyjack Inc. reserves the right to make changes at any time, without notice, to specifications, standard and optional equipment. Consult the Operating Maintenance and Parts Manuals for proper procedures. Work platforms have been tested to comply with ANSI and CSA standards as interpreted by Skyjack Inc.

